

## HAMILTONIAN NONCONTEXTUALITY

A common goal for quantum simulation algorithms is to approximate the ground state energy of some Hamiltonian:

$$H = \sum_{P \in \mathcal{S}} h_P P, \quad (1)$$

where  $\mathcal{S}$  is the set of Pauli terms  $P$ , and  $h_P$  are real coefficients. **Such a Hamiltonian is noncontextual if there exist consistent assignments of simultaneous values ( $\pm 1$ ) to its terms [1].**

## CRITERION FOR NONCONTEXTUALITY

An obstacle to the simultaneous assignment of values to the terms  $\mathcal{S}$  can arise as follows:

If  $A, B$  are commuting Pauli operators, then they can be measured simultaneously, so from the values assigned to them we can infer the value assigned to  $AB$ . In each diagram below, the upper graph shows commutation relations amongst a set of four Pauli operators  $A, B, C, D$ . Each lower graph shows a tree of inferences following from value assignments to  $A, B, C, D$ : each parent node is the product of its children, which commute.

Thus each lower graph implies that the root's value is the product of the leaves' values ( $\pm 1$ ); each leaf appears twice, so the value assigned to the root is  $+1$ . But each root is  $-1$ , so this is a contradiction  $\Rightarrow$  each of these commutation graphs is contextual.

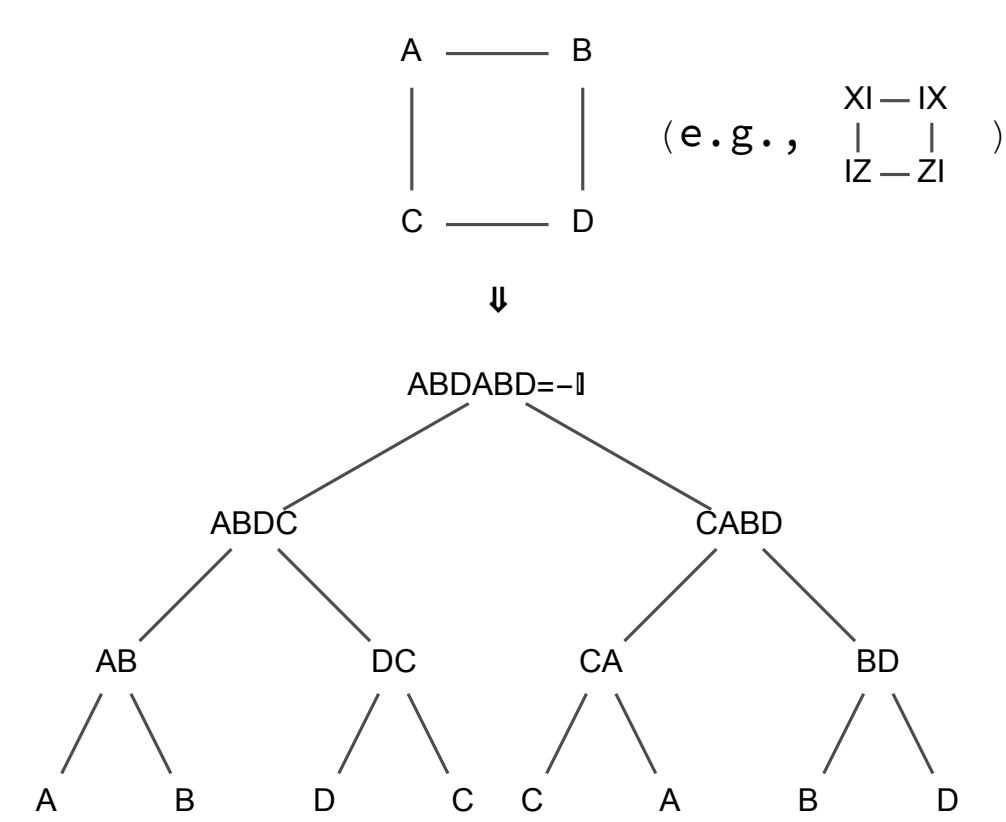
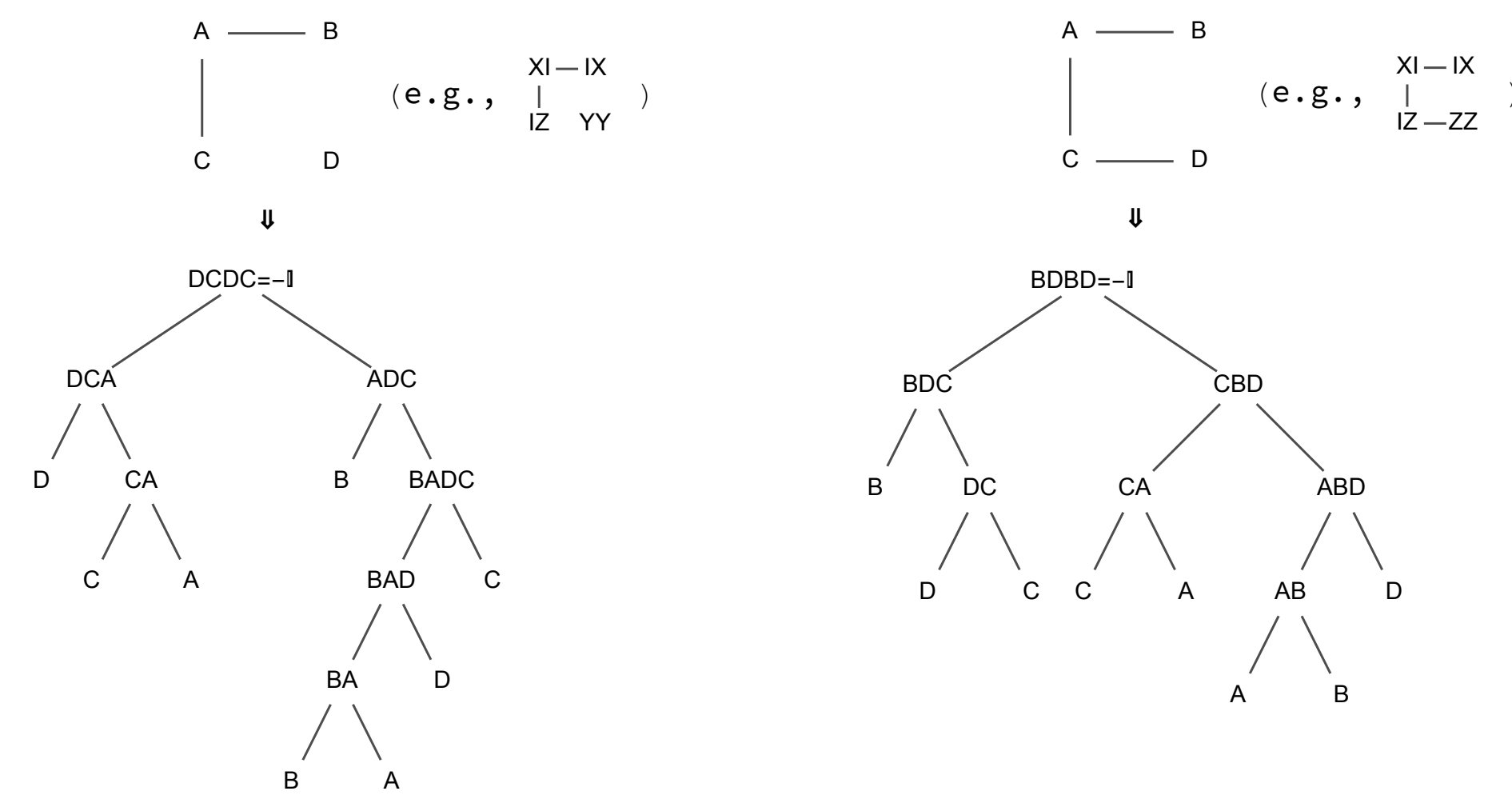

**Hence,  $\mathcal{S}$  is contextual if it contains a subset with one of these commutation graphs. We also proved the reverse: absence of these subgraphs indicates noncontextuality [1].**

## STRUCTURE OF A NONCONTEXTUAL HAMILTONIAN

From the criterion, it follows that a Hamiltonian is *noncontextual* iff its Pauli terms  $\mathcal{S}$  have the following structure:

$$\mathcal{S} = \mathcal{Z} \cup C_1 \cup C_2 \cup \dots \cup C_N, \quad (2)$$

where  $\mathcal{Z}$  is the set of operators in  $\mathcal{S}$  that commute with all others in  $\mathcal{S}$ , operators in the same  $C_i$  commute, and operators in different  $C_i$  anticommute [1]. In other words,  **$\mathcal{S}$  is noncontextual iff commutation is transitive on  $\mathcal{S} \setminus \mathcal{Z}$ .**

Let  $C_i \equiv \{C_{ij} | j = 1, 2, \dots, |C_i|\}$  for each  $i$ ; then for each  $j$ ,  $C_{i1}C_{ij}$  commutes with all operators in  $\mathcal{S}$ . Thus, let  $G$  be a generating set for the commuting set  $\mathcal{Z} \cup \{C_{i1}C_{ij} | i, j\}$ , and let  $\bar{G}$  be the Abelian group generated by  $G$ . Then the Hamiltonian may be written:

$$\begin{aligned} H &= \sum_{P \in \mathcal{S}} h_P P = \sum_{P \in \mathcal{Z}} h_P P + \sum_{i=1}^N \sum_{j=1}^{|C_i|} h_{ij} C_{ij} = \sum_{P \in \mathcal{Z}} h_P P + \sum_{i=1}^N \sum_{j=1}^{|C_i|} h_{ij} \underbrace{C_{i1}C_{i1}}_{\text{insert identity}} C_{ij} \\ \Rightarrow H &= \sum_{B \in \bar{G}} \left( h_B + \sum_{i=1}^N h_{B,i} C_{i1} \right) B, \end{aligned} \quad (3)$$

where each step simply involves reorganizing the expression and/or relabeling the coefficients.

## QUASI-QUANTIZED MODEL

A *quasi-quantized model* is a classical statistical model with an uncertainty relation, comprising a set of "actual" states of the system (*ontic states*), and a set of allowed probability distributions (*epistemic states*) [3].

In our case, the ontic states are joint assignments of values ( $\pm 1$ ) to  $G$  (generating set for  $\mathcal{Z}$ ) and  $\{C_{i1} | i = 1, 2, \dots, N\}$ . Each such assignment induces an assignment to each operator in  $\mathcal{S}$ , as shown in the following diagrams (parent nodes are products of their children, which commute):

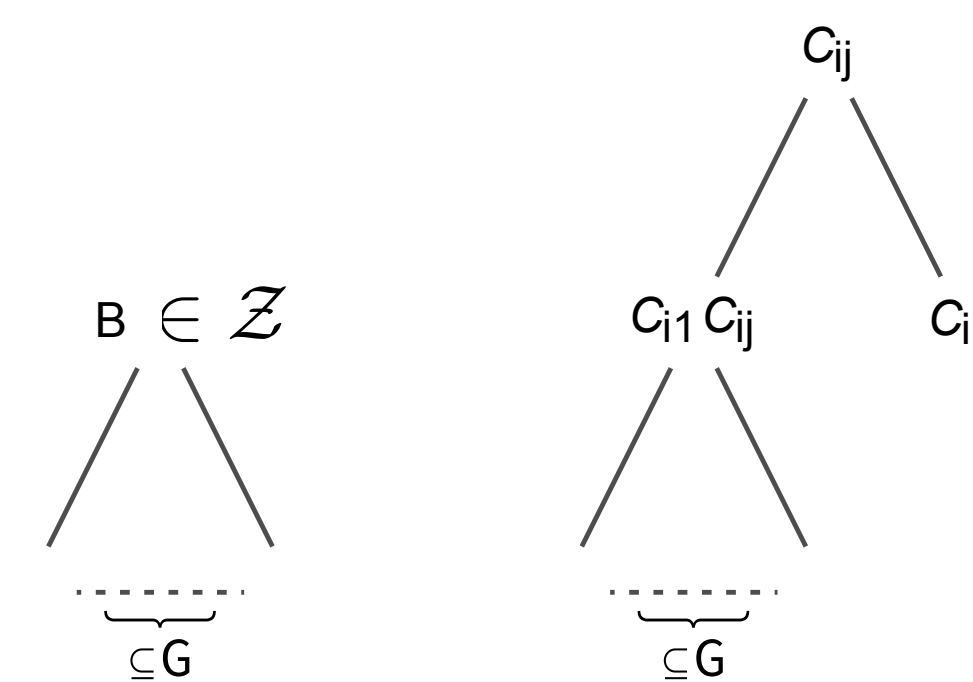

The epistemic states over these ontic states may be expressed as sets of expectation values for  $G \cup \{C_{i1} | i = 1, 2, \dots, N\}$ : the set of allowed epistemic states is

$$\{(\vec{q}, \vec{r}) \in \{\pm 1\}^{|G|} \times \mathbb{R}^N \mid |\vec{r}| = 1\}, \quad \text{where } \langle G_j \rangle = q_j \text{ for each } G_j \in G, \text{ and } \langle C_{i1} \rangle = r_i \forall i. \quad (4)$$

Via (3), each epistemic state gives an expectation value for the Hamiltonian:

$$\langle H \rangle_{(\vec{q}, \vec{r})} = \sum_{B \in \bar{G}} \left( h_B + \sum_{i=1}^N h_{B,i} r_i \right) \prod_{j \in \mathcal{J}_B} q_j, \quad (5)$$

for  $\mathcal{J}_B$  such that  $B = \prod_{j \in \mathcal{J}_B} G_j$ . In [4], we show that the expectation values thus generated always correspond to valid quantum states, and that they include all eigenstates of the Hamiltonian.

We may treat (5) as a classical objective function of an epistemic state  $(\vec{q}, \vec{r})$ , and implement any classical optimization procedure we like to find its minimum. As shown below, this implies that the associated local Hamiltonian problem is NP-complete, so it is not guaranteed to be classically tractable: however, it is unambiguously a classical problem.

## THE NONCONTEXTUAL HAMILTONIAN PROBLEM IS NP-COMPLETE

Using (5), we can obtain any expectation value of the noncontextual Hamiltonian for some set of classical parameters  $(\vec{q}, \vec{r})$ . Thus for any eigenvalue of the Hamiltonian there exists a classical witness  $(\vec{q}, \vec{r})$ . In particular, if the ground state energy of the Hamiltonian is below some value  $a$ , there exists  $(\vec{q}, \vec{r})$  such that  $\langle H \rangle_{(\vec{q}, \vec{r})} < a$ . This proves that the noncontextual Hamiltonian problem is in NP, up to some details given in [4]. Since diagonal Hamiltonians are both NP-complete and noncontextual, **the noncontextual Hamiltonian problem is NP-complete.**

## NONCONTEXTUAL APPROXIMATION

We can also study how noncontextual Hamiltonians can be used to approximate general Hamiltonians. We could then use the classical simulation algorithm for noncontextual Hamiltonians to approximate the ground state energies.

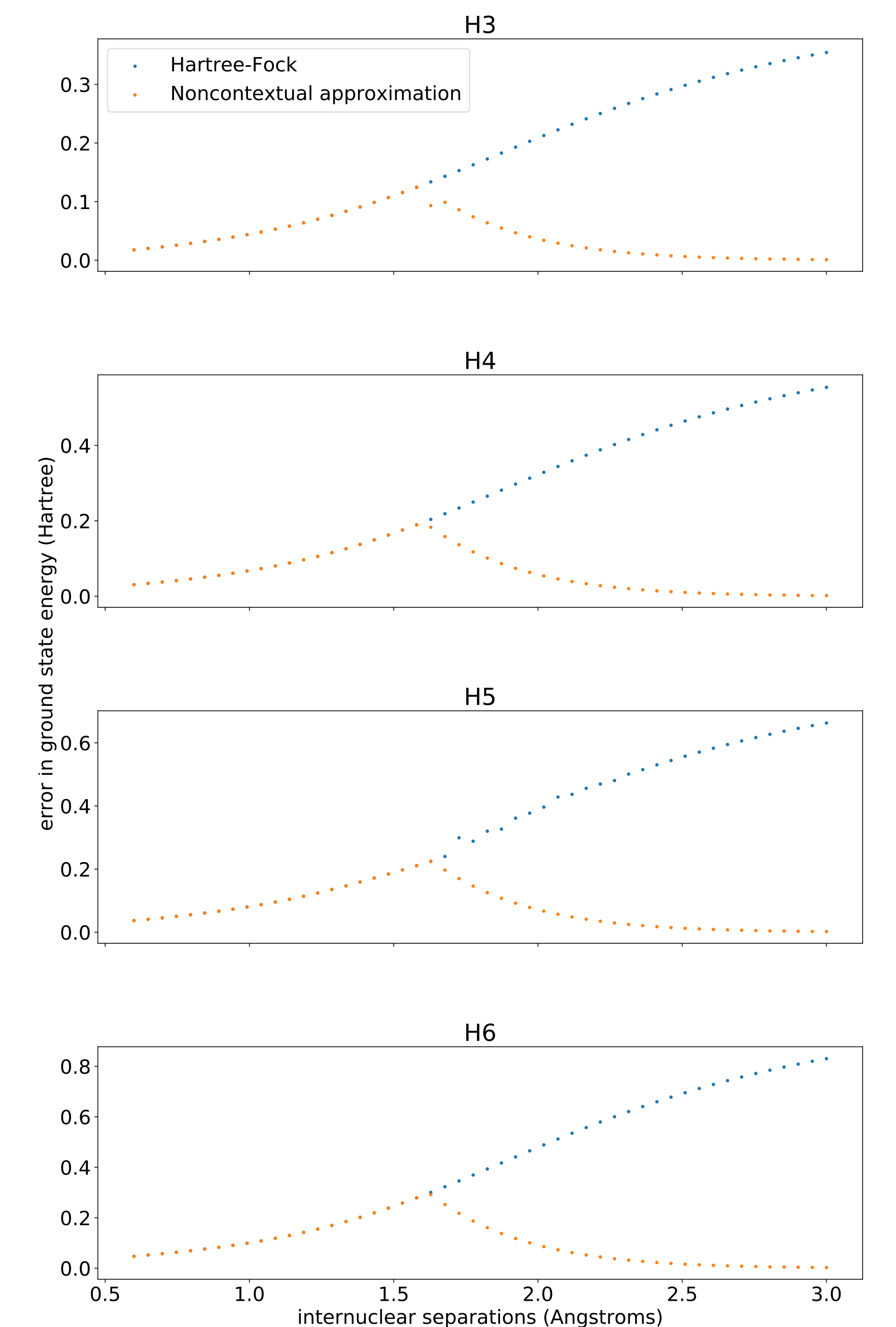

For example, the plots above compare the errors of the Hartree-Fock (HF) method and the noncontextual approximation for Hydrogen chains of three to six atoms, as a function of internuclear separations. As the separations increase, HF steadily loses accuracy, due to the increasing multireference character of the system. **However, using the noncontextual approximation, there is no implicit assumption of a single reference state, so it regains accuracy in the large separation regime.** As many post-Hartree Fock methods in chemistry involve constraining the state space based on excitation away from the reference state, the noncontextual approximation represents a fundamentally different approach to approximating the full Hamiltonian.

## ACKNOWLEDGEMENTS & REFERENCES

W. M. K. acknowledges support from the National Science Foundation, Grant No. DGE-1842474. P. J. L. acknowledges support from the National Science Foundation, Grant No. PHY-1720395, and from Google Inc. This work was supported by the NSF STAQ Grant (PHY-1818914).

- (1) Kirby, W. M.; Love, P. J. *Phys. Rev. Lett.* **2019**, *123*, 200501.
- (2) Peres, A. J. *Phys. A: Math. Theor.* **1991**, *24*, L175; Mermin, N. D. *Phys. Rev. Lett.* **1990**, *27*, 3373-3376.
- (3) Spekkens, R. W. In *Quantum Theory: Informational Foundations and Foils*, Chiribella, G., Spekkens, R. W., Eds.; Springer Netherlands: Dordrecht, 2016, pp 83-135.
- (4) Kirby, W. M.; Love, P. J. *arXiv preprint, arXiv:2002.05693 [quant-ph]* **2020**.